



**John  
BOOS**  
Since 1887

ITEM #: \_\_\_\_\_ QTY: \_\_\_\_\_

MODEL #: \_\_\_\_\_

PROJECT NAME: \_\_\_\_\_

090920

3601 S. Banker St. Effingham, IL 62401 • P.O. BOX 609 • Ph: (888) 431-2667 • Fax: (800) 433-2667

## **"SDS-BB-1" HANDS-FREE SANITIZER DISPENSER STAND**

### **FEATURES:**

- HEAVY DUTY CAST IRON BASE
- UNIVERSAL MOUNTING PLATE - FOR MOUNTING WITH SCREWS OR DOUBLE SIDED TAPE
- POWDER COATED MOUNTING PLATE AND BASE
- ADJUSTABLE FLOOR GLIDES
- EASY ASSEMBLY - KNOCKDOWN DESIGN



BACK MOUNTING PLATE



ADJUSTABLE FLOOR GLIDES



SHOWN WITH HANDS-FREE DISPENSER ATTACHED

### **HANDS-FREE SANITIZER DISPENSER STAND**

MODEL #	QTY
SDS-BB-1	

### **HANDS-FREE SANITIZER DISPENSER**

MODEL #	QTY
PB-SD-2	



HANDS-FREE SANITIZER DISPENSER PB-SD-2 (SOLD SEPARATELY)

SOME UNITS SHIP UNASSEMBLED FOR REDUCED SHIPPING COST. ALL DIMENSIONS ARE TYPICAL. TOLERANCE +/- .500"

John Boos & Co. is constantly engaged in a program of improving products and therefore reserves the right to change specifications without prior notice.

## DETAILED SPECIFICATIONS

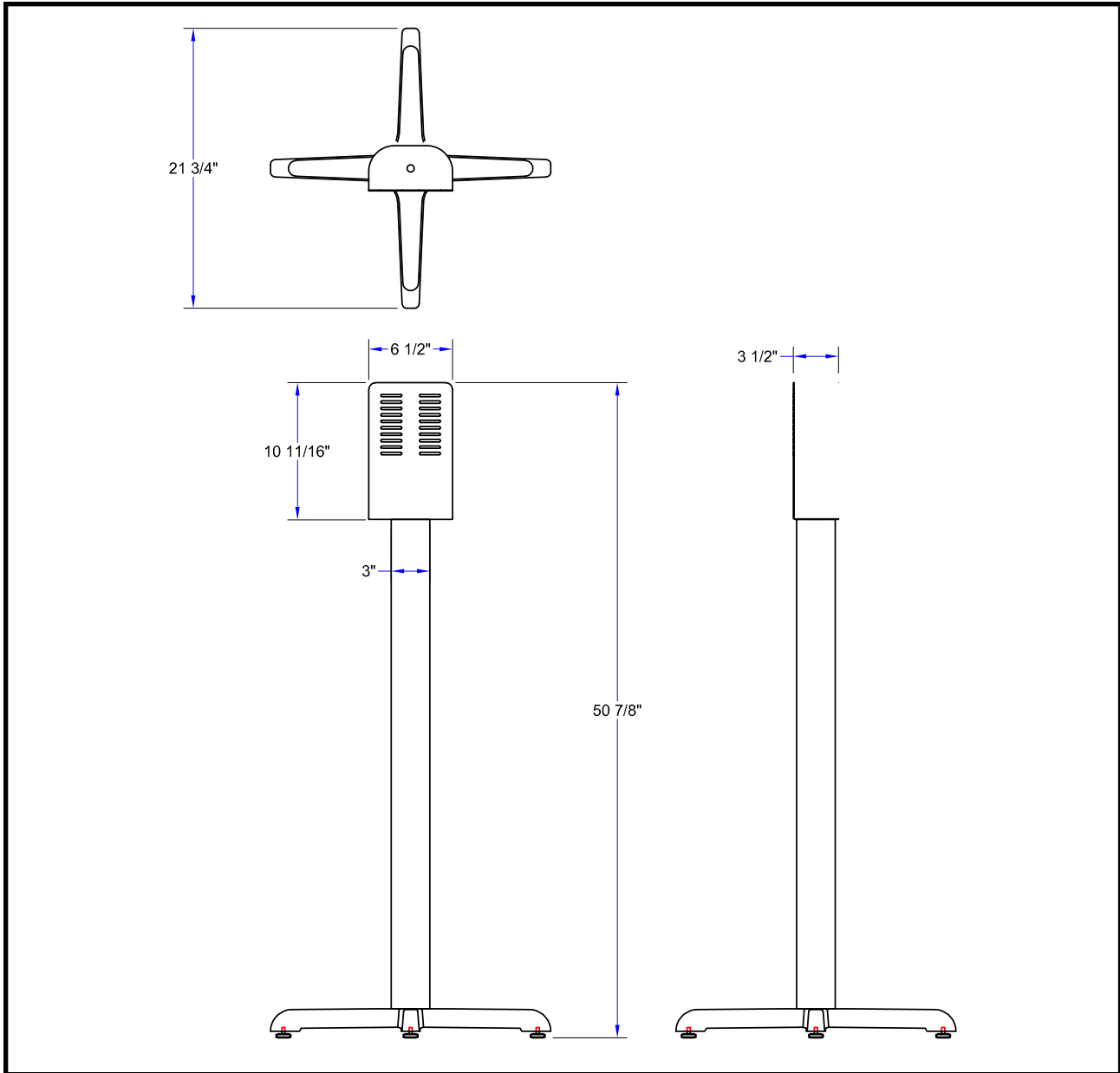

### HANDS-FREE SANITIZER DISPENSER STAND

MODEL #	SIZE (L X W X H)	WEIGHT (LBS)
SDS-BB-1	21-3/4"X21-3/4"X50-7/8"	20

### HANDS-FREE SANITIZER DISPENSER

MODEL #	SIZE (L X W X H)	WEIGHT (LBS)
PB-SD-2	5-1/2"X5-1/2"X12"	2.5

SOME UNITS SHIP UNASSEMBLED FOR REDUCED SHIPPING COST. ALL DIMENSIONS ARE TYPICAL. TOLERANCE +/- .500"  
 John Boos & Co. is constantly engaged in a program of improving products and therefore reserves the right to change specifications without prior notice.



3601 S. Banker St. • Effingham, IL 62401 • PO BOX 609 • quotes@johnboos.com

103020

*Boos*  
lock

AQ AutoQuotes

[www.johnboos.com](http://www.johnboos.com)

1049